



e.thirteen

SRS CHAINGUIDE 2003-2004 SANTA CRUZ V10 INSTALLATION INSTRUCTIONS

Thank you for choosing an e.thirteen SECURITY chain retention device. This chainguide is unlike any other chainguide ever produced. Because of this, the engineers who developed your e.thirteen SECURITY chainguide recommend that you have a trained service technician at your local bike shop install and tune your new guide for optimal performance. You can find local bike shops listed in your yellow pages or online. **EVEN IF YOU ARE AN EXPERIENCED MECHANIC, PLEASE READ THE ENTIRE INSTRUCTION PACKET BEFORE YOU BEGIN INSTALLATION.**

-Some Helpful Information-

Your e.thirteen chainguide is the lightest and strongest chain retention system that we have ever seen. It is extremely free running (no-drag), sheds mud easily, and is easily serviceable. As you learn to use your chainguide, you will find that our bashguard, built from Makrolon™, will allow you to mow through immovable objects at speed. You should inspect your cranks and drive spider frequently for straightness, as huge impacts can bend them. (Imagine what they would look like without the e.thirteen Supercharger bashguard!) Proper installation and frequent cleaning will keep your e.thirteen chainguide running smoothly, quietly, and drag free.

Use only non-ramped standard width chainrings for best performance; wide BMX or DH type chainrings are not recommended.

We recommend the use of e.thirteen brand chainrings for best performance.

IMPORTANT!

-Your new guide is designed to use a flanged fixed cup type bottom bracket when using the supplied ISCG mounting plate.

-It was made to fit a wide variety of frames, but fit up on some frames that were not designed to accept a chainguide may require modification to your guide, frame, or both. Contact your frame manufacturer before any modification of your frame as it may void your warranty.

-Carefully cut the guide parts from the plastic part tree by using a hobby knife. Be sure that the entire tree is removed from the part. Use only a knife as wire cutters; scissors, etc. may damage the part.

- Parts List:**
- 1 – Back Plate
 - 1 – ISCG mount (not shown)
 - 1 – Parts tree (upper slider, lower slider, outer slider, and idler)
 - 1 – idler bearing
 - 1 – Polycarbonate Bashring (not shown)
 - 2 – m4 x 18 mm Flathead screws
 - 2 – m6 x 25 mm Cap screws
 - 2 – m4 nylon insert locking nuts
 - 2 – m6 nylon insert locking nuts
 - 3 – m6 x 10 mm Flathead screws
 - 3 – m6 x 16 mm Flathead screws
 - 5 – m8 washers
 - 4 or 5 – Ex. long chainring bolts
 - 4 or 5 – Ex. long chainring nuts
 - 15 – m6 washers



INSTRUCTIONS FOR 2003 SANTA CRUZ V10 FRAMES WITHOUT INTERNATIONAL STANDARD CHAINGUIDE TABS

1)! Inspect all existing drivetrain components to determine straightness! Your new chainguide was designed to protect your drivetrain, but performance will be hindered by out-of-round spiders and chainrings, or bent bottom bracket spindles. For your own safety you should replace any damaged components on your bike before riding it. **Bent parts=bad performance!**

2) Remove both crank arms, chainrings, chain, and drive side bottom bracket cup. Also loosen the non-drive side bottom bracket cup 2-3 turns.

3) Fit up the ISCG mount flange to your frame. For installation on a 2002-2003 Santa Cruz V10, the counter bored area cups away from the bottom bracket shell. See **Fig. 1a and 1b**. The V10 uses a 128 mm spindle length ISIS BB. The 128mm BB will give best chainline. If you are unable to purchase a 128 mm spindle BB, a 122.5mm BB can be used with a 1.5 mm BB spacer between the ISCG mount flange and BB shell. Use your flanged fixed cup type bottom bracket to sandwich the ISCG mount flange against the flat face of the bottom bracket shell. The open side of the flange should be facing the 10 o'clock position. See **Fig. 1a and 1b**. for ISCG mount flange orientation.

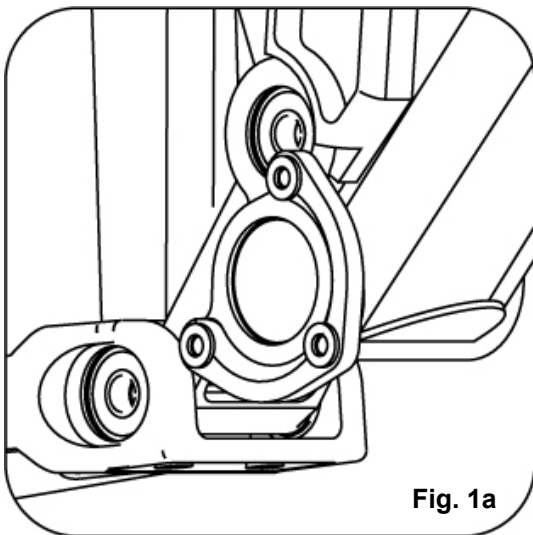

Fig. 1a

4) Snug your flange type bottom bracket into the threads in the BB shell per normal BB installation. Follow the torque specification recommended by Santa Cruz or your bottom bracket maker.

5) Install upper slider on to back plate using the supplied 4 mm bolts and nuts. The upper slider has two positions on the rear-mounting hole for long-travel suspension/hardtail adjustments as shown in **Fig. 2**. The Santa Cruz V10 will use the long travel position shown in **Fig. 2**. Place the 4 mm nyloc nuts in the slots on the frame side of the back plate as shown in **Fig. 3**. Place the upper slider on the crank side of the back plate. Fasten with two m4 socket head cap screws. (Use a 2.5 mm Allen wrench) Do not tighten M4 screws yet, as adjustment will be needed later.

3 washers between plate and reversed ISCG mount	Long travel top slider position (bottom bolt hole)	Position lock nuts in slots

Fig. 1b

Fig. 2

Fig. 3

The upper slider is positioned as pictured in **Fig. 2**. The Santa Cruz V10 frame uses low hanging suspension components requires the use of the long travel top slider bolt position. Do not tighten bolts, as later adjustment is needed. **Note: NEVER space out the slider from the back plate with washers!**

5a) Press the supplied bearing into your roller using a press or vise. **Do not use a hammer to install the bearing, as crooked installation can destroy the roller.**

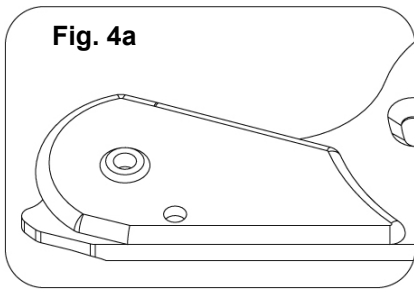

Fig. 4a

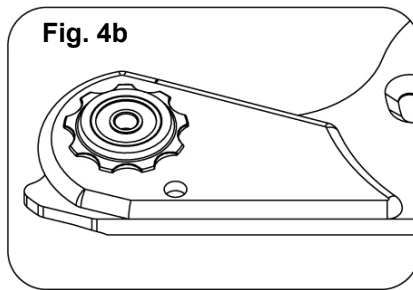

Fig. 4b

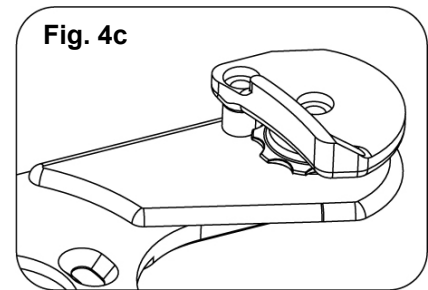

Fig. 4c

6) Installing lower slider and chain idler: Place the lower slider on the crank side of back plate as shown in **Fig. 4a**. Next place the idler pulley on top of the lower slider; the hole of the idler should match up with the upper hole on the lower slider as shown in **Fig. 4b**.

Next place the lower outer slider on top of the chain idler as shown in **Fig. 4c**. Place a 2 M6 cap screw thru the hole of the outer plate, the chain idler, lower slider and back plate; carefully place a m6 nyloc nut on each screw in the slots on the back side of the back plate. Carefully thread the bolt into the nut, tighten loosely. (Use a 5 mm Allen wrench). Do not tighten M6 bolts yet, as adjustment will be needed later.

7) Mount the entire slider/back plate assembly to the ISCG mount flange using the on of the 2 sets of three equal length M6 flathead screws. The two lengths of screws that are included with your chainguide are for use with the appropriate number of washers. For the V10, space the back plate away from the ISCG mount using ONE set of the supplied washers as shown in **Fig. 1a and 1b**.

8) Mount your sprocket in the MIDDLE RING position on your spider. Using the included extra long steel chainring nuts, mount the polycarbonate bashring to the OUTER RING position. The nuts should pass through the middle ring from the backside, then through the spider, and into the bash guard. Line up the relief in the outside of the bash guard with the crank arm. The crank relief should be facing outwards, away from the frame. **Use one of the included big washers under the head of each chainring bolt and tighten the chainring bolts until they are torqued to 43 in-lbs..**

V10 Chainguide rotation orientation

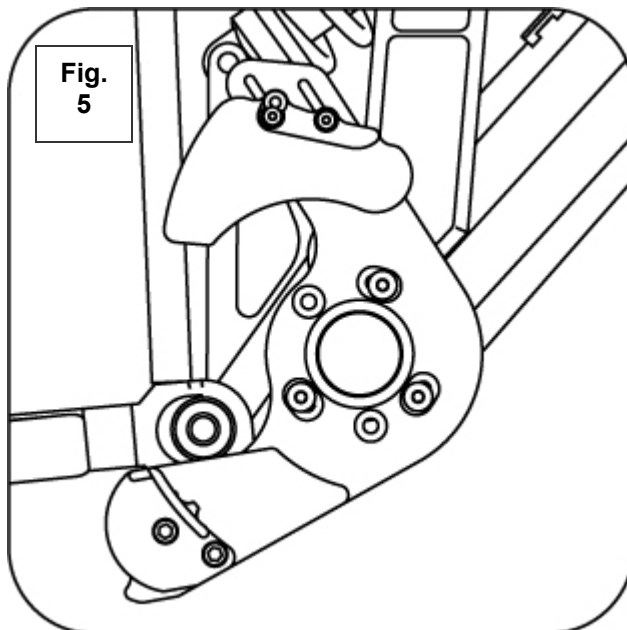

Fig. 5

Re-mount the chain onto the middle ring, and fit your cranks to the bottom bracket spindle. Tighten the cranks all the way down. Check the distance between your chainring and the back plate. **Add or subtract washers from BETWEEN the ISCG mount and the BACK PLATE** so that the outer surface of the guide alignment ridge on the lower outer slider is parallel to and at the same level as the outside surface of the bash guard. (SEE FIG. 6)

This may take a few tries if you are not using the 128 mm spindle BB.

All Santa Cruz V10 frames with a 128 mm BB spindle will use ONE WASHER in between the ISCG mount and back plate as shown in Fig. 1a and 1b.

The upper slider should be spaced approx. 1 mm from the inside of the bashguard. The upper slider portion of the back plate is designed to be bent (with a fair amount of force) closer to the chainring for fine tuning if needed. This is usually not necessary

9) Adjust the upper slider so that the lower surface of the slider is about 3 mm (1/8 inch) from the top of the chain. Torque the M6 screws to 8 in-lbs.

10) Adjust the lower slider so that is about 3 mm (1/8 inch) from the bashguard. Torque the M4 screws to 3.5 in-lbs.

11) Using the mounting slots, adjust rotation of entire chainguide, so that the chainguide assembly is rotated as far clockwise as needed. See correct rotation in **Fig. 5**.

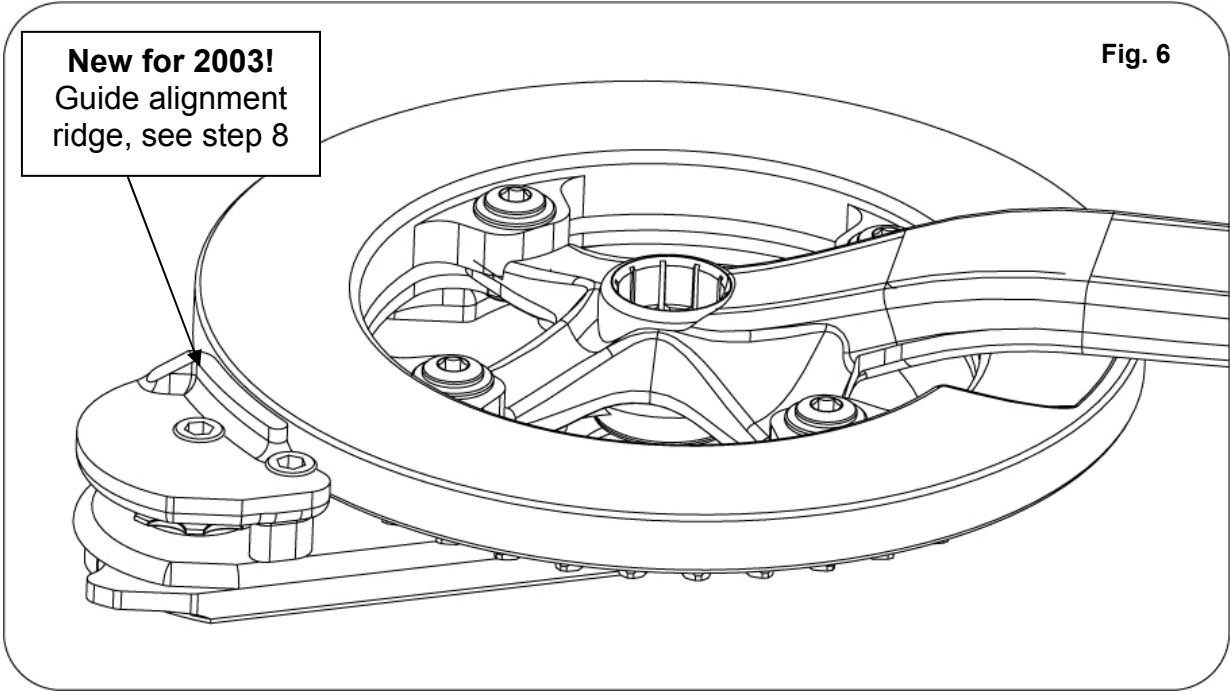

Fig. 6

Chainguide visual alignment using alignment tab

Back plate spaced too far outwards. Remove spacer washers.

Back plate spaced too far inwards. Add spacer washers.

Alignment ridge and bashguard are flush. Perfect Alignment!

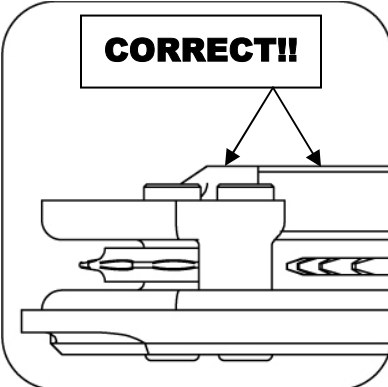
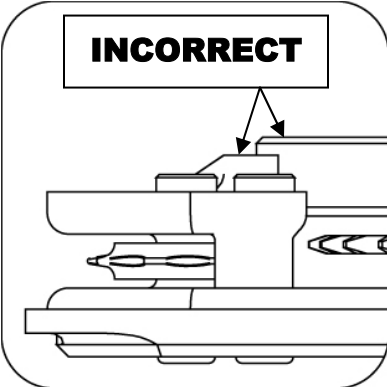
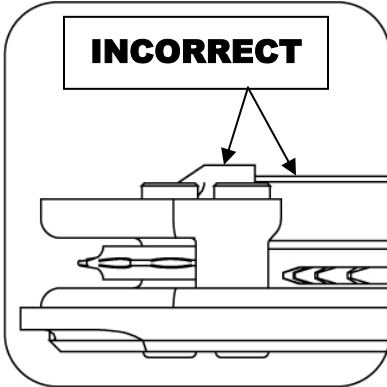

IMPORTANT NOTE: Always rotate chainguide as far clockwise as possible to reduce possibility of lower idler hitting obstacles. See Fig. 5.

NOTE: Updated and printable instructions and pictures of guides on different frames are available at <http://www.e13components.com>. Guide performance is directly related to setup. Check your guide to make sure it is in adjustment after every run to minimize the possibility of failure. If you have a problem with or question about your e.thirteen SECURITY chainguide, contact e.thirteen via e-mail at support@e13components.com.