



e.thirteen

SRS / STS / 32Special CHAINGUIDE INSTALLATION INSTRUCTIONS

Thank you for purchasing an e.thirteen SECURITY chain retention device. Our Single Ring Retention systems are unlike any other chainguide ever produced. Because of this, the engineers who developed your e.thirteen SECURITY chainguide recommend that you have a trained service technician at your local bike shop install and tune your new guide for optimal performance. You can find local bike shops listed in your yellow pages or online.

EVEN IF YOU ARE AN EXPERIENCED MECHANIC, PLEASE READ THE ENTIRE INSTRUCTION PACKET BEFORE YOU BEGIN INSTALLATION.

-Some Helpful Information-

Your e.thirteen chainguide is the best combination of light weight and high strength on the market today. It is extremely free running (no-drag), sheds mud easily, and is easily serviceable. As you learn to use your chainguide, you will find that our bashguard, built from proprietary alloys, will allow you to mow through immovable objects at speed. You should inspect your cranks, BB spindle, and spider frequently for straightness, as huge impacts can bend them while hardly affecting the e.thirteen Supercharger bashguard. Proper installation and frequent cleaning will keep your e.thirteen chainguide running smoothly, quietly, and drag free.

Use only non-ramped, standard width (3mm thick) chainrings for best performance; wide BMX or DH type chainrings are not recommended.

We recommend the use of our e.thirteen chainrings for best performance.

IMPORTANT!

- Your new guide is designed to use a flanged fixed cup type bottom bracket when using the supplied ISCG mounting plate.
- It was made to fit a wide variety of frames, but fit up on some frames that were not designed to accept a chainguide may require modification to your guide, frame, or both. Contact your frame manufacturer before any modification of your frame as it may void your warranty.

Parts List:

- 1 - Back Plate
- 1 - ISCG Adapter Plate
- 3 - Wearplates (upper slider, lower slider, outer slider)
- 1 - Tech 2 Sealed bearing idler
- 1 - Tuffmax Bashguard (not shown)
- 2 - M4 x 14 mm Cap screws
- 2 - M5 x 25 mm Cap screws
- 2 - M4 nylon insert locking nuts
- 2 - M5 nylon insert locking nuts
- 3 - M6 x 10 mm Flathead screws
- 3 - M6 x 16 mm Flathead screws
- 4 or 5 - M8 washers
- 4 or 5 - Ex. long chainring bolts
- 4 or 5 - Ex. long chainring nuts
- 9 - M6 x 2.5 mm chainline spacers (black)
- 3 - M6 x 1.25 mm chainline spacers (gold)



**INSTRUCTIONS FOR FRAMES WITHOUT
INTERNATIONAL STANDARD CHAIN GUIDE MOUNT**

1) Inspect all existing drivetrain components to determine straightness! Your new chainguide was designed to protect your drivetrain, but performance will be hindered by out-of-round spiders and chainrings, or bent bottom bracket spindles. For your own safety you should replace any damaged components on your bike before riding it. Bent parts = bad performance!

2) Remove both crank arms, chainrings, chain, and drive side bottom bracket cup. Also loosen the non-drive side bottom bracket cup 2-3 turns.

3) Fit up the ISCG mount flange to your frame. For a normal installation, the counter bored side cups over the bottom bracket shell. For spindle lengths of 125 mm and over, OR on frames that were not designed to accept a chain guide you can mount ISCG mount flange with the cupped side facing away from the bottom bracket shell. Use your flanged fixed cup type bottom bracket to sandwich the ISCG mount flange against the flat face of the bottom bracket shell. The upper hole on the mount should be about at the 1 o'clock position. See Fig 1a and 1b for approximate ISCG mount flange orientation.

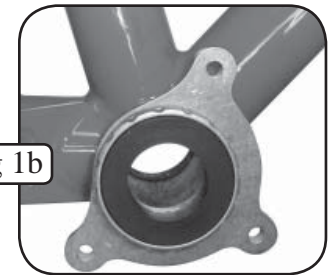
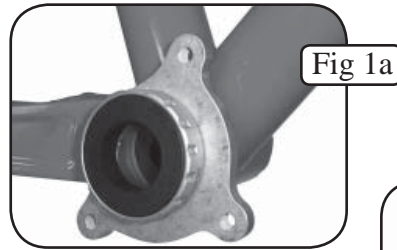

4) Snug your flange type bottom bracket into the threads in the BB shell per normal BB installation.

Tip: Grease only the threads inside the BB shell of the frame; grease on the threads of the BB cup will pile up and get between the clamped surfaces, thus reducing the friction between the components and increasing the chances of the ISCG adapter plate slipping. Follow the torque specification recommended by your bottom bracket manufacturer.

5) Mount the entire guide assembly to the ISCG mount flange using one of the 2 sets of three equal length M6 flathead screws. The two lengths of screws that are included with your chainguide are for use with the appropriate number of washers. If needed, space the back plate away from the ISCG mount with the supplied washers. The Table 1 below is a suggested starting place for spacing out the backplate.

Table 1

BB SHELL WIDTH	CHAINLINE	TYPICAL BB SPINDLE LENGTH	TYPICAL # OF SPACER WASHERS NEEDED	
			BLACK (2.5mm)	GOLD (1.25mm)
68	47.5	113	0	FINE TUNE
68 or 73	50	113	0	FINE TUNE
68 or 73	52.5	118	1	FINE TUNE
68 or 73	55	123	2	FINE TUNE
68 or 73	57.5	128	3	FINE TUNE
83	57.5	128	1	FINE TUNE
83	60	133	2	FINE TUNE
100	63.5	140	0	FINE TUNE
100	65	145	1	FINE TUNE

6) Mount your sprocket in the MIDDLE RING position on your spider. Using the included extra long steel chainring nuts, mount the polycarbonate bashring to the OUTER RING position. The nuts should pass through the middle ring from the backside, then through the spider, and into the bash guard. Line up the relief in the outside of the bash guard with the crank arm. The crank relief should be facing outwards, away from the frame. Use one of the included M8 washers under the head of each chainring bolt, as seen in Fig 2, and torque the chainring bolts to **43 in-lbs.**

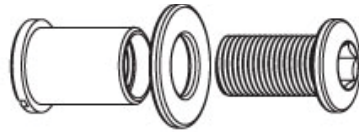
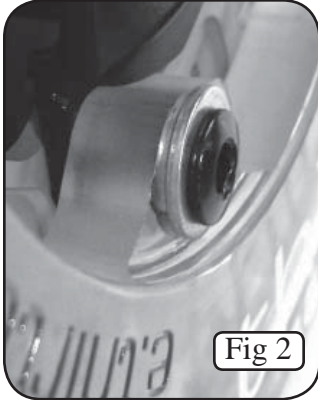

Over tightening and/or the use of loctite will crack the bashguard.

Tip: 43 in-lbs. = about as much force as you can generate by holding the SHORT end of an “L-Shaped” 5mm Allen Wrench

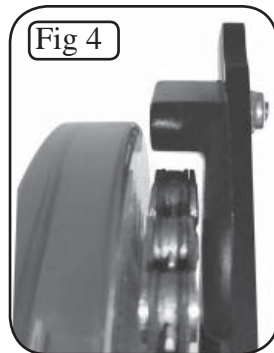
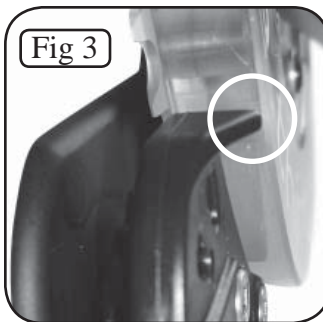

7) Re-mount the chain onto the middle ring, and fit your cranks to the bottom bracket spindle. Tighten the cranks all the way down. Check the distance between your chainring and the back plate. Add or subtract chainring spacers (refer to Table 1) from BETWEEN the ISCG mount and the BACK PLATE so that the outer surface of the guide alignment ridge on the lower outer slider is parallel to and at the same level as the outside surface of the bash guard (as seen in Fig 3). The upper slider should be spaced approx. 1 mm from the inside of the bash guard (as seen in Fig 4) The upper arm of the back plate is designed to be bent (with a fair amount of force) closer to the chainring for fine tuning if needed. This is usually not necessary.

Warning! DO NOT use the chainring spacers to space the wearplates out from the backplate! Chainring spacers should ONLY be used to space the backplate out from the ISCG adapter plate.

8) Adjust the height of the upper slider so that the lower surface of the slider is about 3 mm (1/8 inch) from the top of the chain (as seen in Fig 5). Torque the screws to 3.5 in-lbs (about as much force as you can generate by holding the SHORT end of an “L-Shaped” 3mm Allen Wrench).

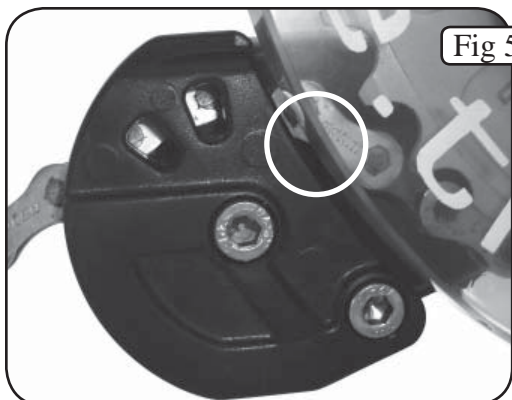

9) Adjust the lower slider so that it is about 3 mm (1/8 inch) from the bash guard (as seen in Fig 6). Torque the screws to 8 in-lbs (just a couple of turns past finger tight; the nyloc nut will hold it tight).

10) Using the three mounting slots around the center hole of the backplate, adjust rotation of entire chainguide assembly so that the bolts holding the upper slider are at 12 o'clock, and tighten down the M6 bolts holding the backplate to the ISCG mounts. See correct rotation in Figure 8 (following page).

INSTRUCTIONS FOR FRAMES **WITH**
INTERNATIONAL STANDARD CHAINGUIDE TABS

- 1) Remove the drive side crank from bottom bracket.
- 2) Follow steps 5-10 of the previous set of instructions.
- 3) Use supplied bolts and chainline spacers to bolt the guide mount plate to the international standard mount tabs on your frame.

Warning! DO NOT use the chainline spacers to space the wearplates out from the backplate! Chainline spacers should ONLY be used to space the backplate out from the ISCG tabs on your frame.

IMPORTANT!! We have found that many frame manufacturers weld tabs on incorrectly, rotated to the wrong position, weld crooked or weld too far away from the edge of the BB shell. Some frame manufacturers have invented their own "standards" for chainguide mounting. The SECURITY chainguide system supports the ISCG or ISCG05 standard. Your guide may or may not fit other mounting systems.

SRS CORRECT SETUP

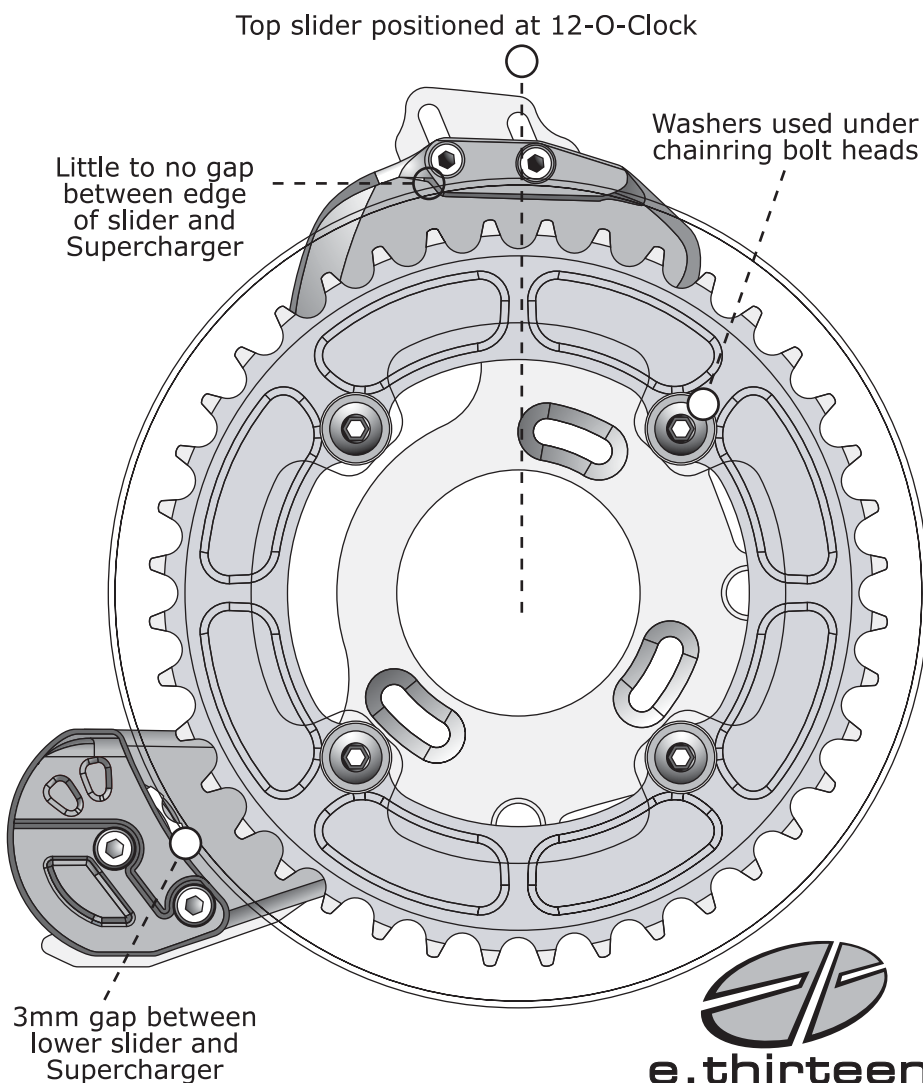

NOTE: Updated and printable instructions and pictures of guides on different frames are available at www.e13components.com. Guide performance is directly related to setup. Check your guide to make sure it is in adjustment after every run to minimize the possibility of failure. If you have any questions about your e.thirteen SECURITY chainguide, contact e.thirteen via e-mail at

support@e13components.com.

e.thirteen components
Business Office:
98 Preble St.
Portland, ME 04101
207.772.3132
www.e13components.com